



SERVICE PARTS LIST

BULLETIN NO.
54-24-0140

SPECIFY CATALOG NO. AND SERIAL NO. WHEN ORDERING PARTS			REVISED BULLETIN	DATE
1-9/16" (40mm) SDS-Max Rotary Hammer				Feb. 2024
CATALOG NO.	5517-20	SERIAL NO.	WIRING INSTRUCTION	
		N89A	SEE PAGE 5 thru 7	

● = Component of
14-46-0496
5517-20 General
Maintenance
Service Kit (See
page 3 for complete
BOM of kit)

FIG.	PART NO.	DESCRIPTION OF PART	NO. REQ.
22	28-14-0028	Mid Gearcase Svc. Kit (Components also on page 2)	(1)
22a	-----	Mid Gearcase	(1)
22c	43-84-0031 ●	Felt Plug	(2)
22d	36-17-0021	Crank Shaft	(1)
22e	-----	Bevel Retaining Ring	(1)
22f	-----	Ball Bearing	(1)
22g	-----	Snap Ring	(1)
22h	-----	Crank Gear	(1)
22j	-----	Retaining Ring	(1)
22m	45-88-0241	Flat Washer	(8)
22n	05-90-0105	Spring Washer	(2)
32b	06-82-2873	M5 x 17mm Pan Hd. T-25 Machine Screw	(2)
32c	06-82-2873	M5 x 17mm Pan Hd. T-25 Machine Screw	(6)
34	14-26-0115	M-Clutch Service Assembly	(1)
34a	-----	Bevel Pinion	(1)
34b	-----	Clutch Bearing	(1)
34c	-----	Clutch Driver	(1)
34d	-----	Clutch Roller	(8)
34e	-----	Long Clutch Spring	(8)
34f	-----	Clutch Gear	(1)
34g	-----	Retaining Ring	(1)
35	02-50-0013	Thrust Needle Bearing	(1)
36	45-88-0246	Thrust Bearing Washer	(1)
37	43-44-0118 ●	Lower Gearcase Gasket	(1)
38	28-14-0043	Lower Gearcase Service Assembly	(1)
38a	-----	Dowel Pin	(2)
38b	-----	Needle Bearing	(1)
38c	43-42-0093 ●	Motor Shaft Seal	(1)
38d	-----	Needle Bearing	(1)
38e	-----	Lower Gearcase	(1)
39	16-07-0025	120V Service Armature Assembly	(1)
39a	-----	C-Ring	(1)
39b	-----	Ball Bearing	(1)
39c	-----	Retaining Plate	(1)
39d	-----	120V Armature	(1)
39e	-----	Ball Bearing	(1)
39f	-----	Rubber Cap	(1)
40	05-78-0032	M5 x 13mm Pan Hd. T-25 Machine Screw	(2)
41	05-88-1275	M4 x 70mm Pan Hd. Phillips ST Screw	(2)
42	31-05-0021	Fan Baffle	(1)
43	14-20-0352	120 V Service Field	(1)
44	31-15-0113	Housing Cover	(1)
45	31-44-0282	Housing Support	(1)
46	05-78-5311	M5 x 18mm Pan Hd. T-20 PT Screw	(9)
47	28-50-0038	Motor Housing	(1)
48	05-78-0019	M5 x 25mm Pan Hd. T-25 Machine Screw	(4)
49	05-78-5313	M4 x 9mm Pan Hd. T-15 ST Screw	(2)
50	31-12-0109	Motor Cap	(1)
51	-----	Right Carbon Brush	(1)
52	22-22-0021	Brush Holder Assembly	(2)
53	-----	Left Carbon Brush	(1)
54	06-82-0044	M4 x 18mm Pan Hd. T-20 ST Screw	(4)
55	14-34-0111	Auxiliary Side Handle Assembly	(1)
55a	-----	Auxiliary Handle Clamp	(1)
55b	-----	Square Nut	(1)
55c	-----	Clamp Holder	(1)
55d	-----	Side Handle	(1)
56	06-82-8828	#8-32 Pan Hd. T-20 Taptite Screw	(1)
57	22-90-0040	AVS Rubber	(1)
58	31-44-0280	Rear Handle Service Kit	(1)
58a	-----	Rear Handle Support	(1)
58b	-----	Rear Handle Cover	(1)
58c	31-86-0022	Handle Foam Bushing, 3mm	(2)
58d	42-42-0054	Handle Foam Bushing	(2)
59	14-20-0332	PCBA	(1)
60	31-92-0053	Trigger Cap	(1)
61	23-66-0103	On-Off Switch	(1)
62	06-82-0995	M4 x 16mm Pan Hd. T-20 ST Screw	(2)
63	31-17-0026	Cord Clamp	(1)
64	22-64-0134	120V Power Cord	(1)
65	23-94-0048	120V Ground Wire	(1)
69	22-56-5317	Close End Connector	(3)
71	12-20-0450	Service Nameplate (Not Shown)	(1)
72	42-55-0111	Blow Molded Carrying Case	(1)
80	22-16-0031	Brush Service Kit (Set of two brushes)	(1)

00 **0** **EXAMPLE:**
Component Parts (Small #) Are Included
When Ordering The Assembly (Large #).

● = Component of the **14-46-0496**
5517-20 General Maintenance Service Kit
See page three for a complete BOM of this kit.

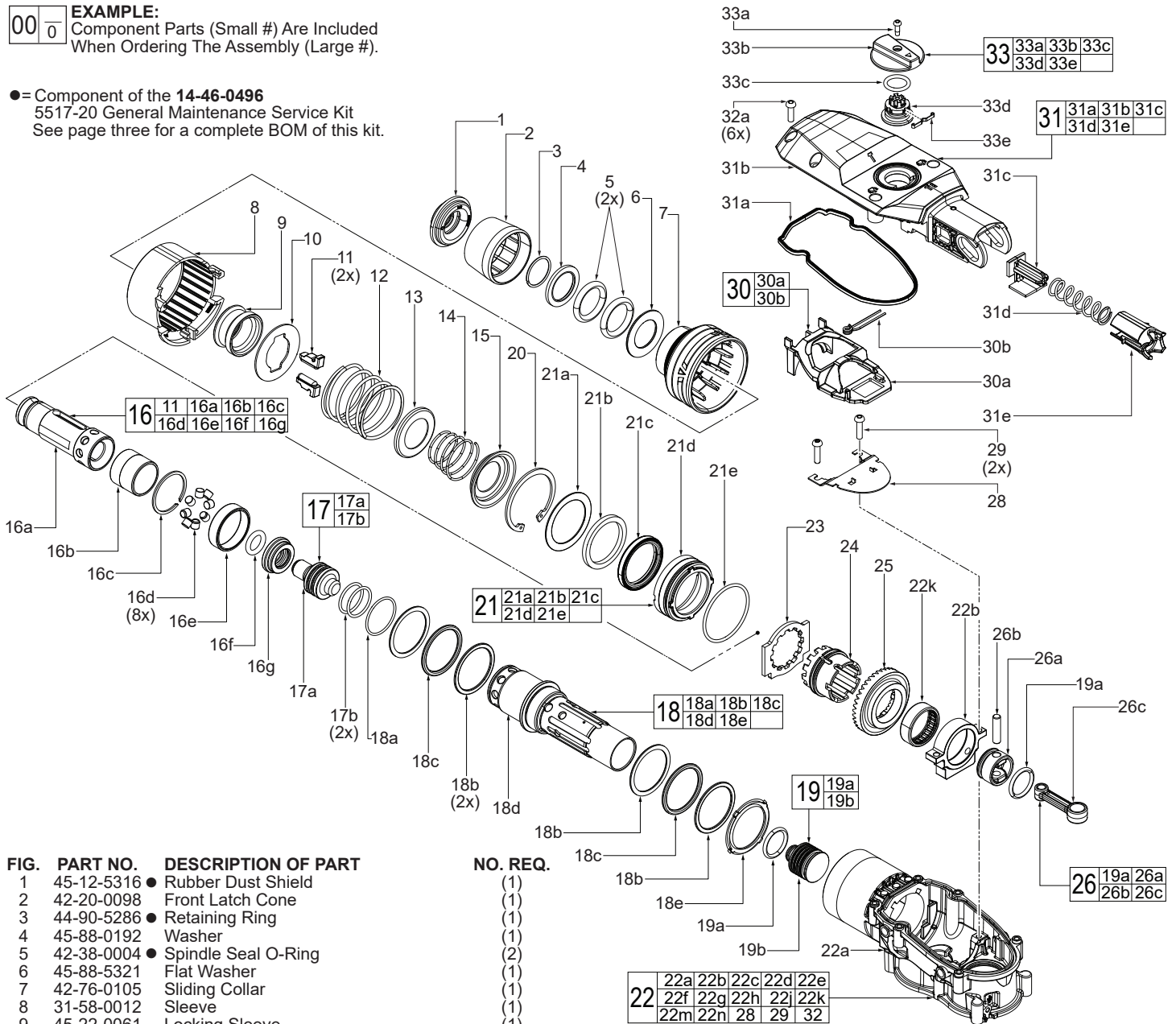

FIG.	PART NO.	DESCRIPTION OF PART	NO. REQ.
1	45-12-5316	● Rubber Dust Shield	(1)
2	42-20-0098	Front Latch Cone	(1)
3	44-90-5286	● Retaining Ring	(1)
4	45-88-0192	Washer	(1)
5	42-38-0004	● Spindle Seal O-Ring	(2)
6	45-88-5321	Flat Washer	(1)
7	42-76-0105	Sliding Collar	(1)
8	31-58-0012	Sleeve	(1)
9	45-22-0061	Locking Sleeve	(1)
10	34-40-0231	Retaining Plate	(1)
11	42-68-0071	● Double Spring Latch	(2)
12	40-50-0481	Chuck Spring	(1)
13	45-88-0306	Double Spring Latch Washer	(1)
14	40-50-0466	Cone Spring	(1)
15	40-50-0482	Spring Retainer	(1)
16	38-50-0071	SDS Max Front Spindle Service Assembly	(1)
16a	-----	SDS Max Spindle Driver	(1)
16b	-----	Anvil Sleeve	(1)
16c	44-90-1002	● Spindle Cap Snap Ring	(1)
16d	44-60-7044	● Spindle Pins	(8)
16e	-----	● Spindle Cap	(1)
16f	34-40-0446	● Striker Catch O-Ring	(1)
16g	-----	Anvil Guide	(1)
17	14-46-0362	Anvil Service Assembly	(1)
17a	-----	Anvil	(1)
17b	34-40-0447	● Anvil O-Ring	(2)
18	38-50-0072	5Kg Spindle Service Assembly	(1)
18a	34-40-0301	● Front Spindle O-Ring	(1)
18b	-----	Spindle Bumper Washer	(4)
18c	34-40-0331	● Spindle Bumper Ring	(2)
18d	-----	Spindle Sleeve	(1)
18e	-----	Tab Washer	(1)
19	42-62-0117	Striker Service Assembly	(1)
19a	34-40-0448	● Striker/Piston O-Ring	(1)
19b	-----	Striker	(1)
20	34-40-5315	C Retaining Ring	(1)
21	42-40-0016	Front Spindle Bushing Service Kit	(1)
21a	45-88-0433	● Spindle Seal Cup Washer	(1)
21b	43-44-0091	● Felt Seal	(1)
21c	43-44-0092	● Spindle Lip Seal	(1)
21d	-----	● Front Spindle Bushing	(1)

FIG.	PART NO.	DESCRIPTION OF PART	NO. REQ.
21e	34-40-0333	● Front Bushing O-Ring	(1)
22	28-14-0028	Mid Gearcase Svc. Kit (Components also on page 1)	(1)
22a	-----	Mid-Gearcase	(1)
22b	-----	● Rear Bushing	(1)
22k	-----	Needle Bearing	(1)
23	44-66-0271	Locking Plate	(1)
24	31-50-0273	Mode Select Collar	(1)
25	32-05-0041	Bevel Gear	(1)
26	44-62-0054	Piston Service Assembly	(1)
26a	-----	Piston	(1)
26b	-----	Wrist Pin	(1)
26c	-----	Connector Rod	(1)
28	42-92-0277	Fork Support Plate	(1)
29	05-78-0033	M5 x 20mm Pan Hd. T-25 Machine Screw	(2)
30	14-46-0443	Fork Service Assembly	(1)
30a	-----	Fork	(1)
30b	-----	Fork Spring	(1)
31	14-30-0152	Gearcase Cover Service Assembly	(1)
31a	43-44-0008	● Gearcase Cover Gasket	(1)
31b	-----	Gearcase Cover	(1)
31c	40-50-0214	Spring Holder	(1)
31d	40-50-0421	Spring	(1)
31e	43-56-0011	Handle Spring Carrier	(1)
32a	06-82-2873	M5 x 17mm Pan Hd. T-25 Machine Screw	(6)
33	43-98-0123	Selector Knob Service Kit	(1)
33a	06-82-0032	M4 x 12mm Pan Hd. T-20 ST Screw	(1)
33b	-----	Selector Knob	(1)
33c	34-40-0449	● O-Ring	(1)
33d	-----	Mode Selector Cam	(1)
33e	40-50-0224	H Spring	(1)

General Maintenance Service Kit

FIG.	PART NO.	DESCRIPTION OF PART	NO. REQ.
1	45-12-5316	Rubber Dust Shield	(1)
3	44-90-5286	Retaining Ring	(1)
5	42-38-0004	Spindle Seal O-Ring	(2)
11	42-68-0071	Double Spring Latch	(2)
16c	34-60-0034	Spindle Cap Snap Ring	(1)
16d	06-65-0154	Spindle Pins	(8)
16e	-----	Spindle Cap	(1)
16f	34-40-0446	Striker Catch O-Ring	(1)
17b	34-40-0447	Anvil O-Ring	(2)
18a	34-40-0301	Front Spindle O-Ring	(1)
18c	34-40-0331	Spindle Bumper Ring	(2)
19a	34-40-0448	Striker/Piston O-Ring	(1)
21a	45-88-0433	Spindle Seal Cup Washer	(1)
21b	43-44-0091	Felt Seal	(1)
21c	43-44-0092	Spindle Lip Seal	(1)
21d	-----	Front Spindle Bushing	(1)
21e	34-40-0333	Front Bushing O-Ring	(1)
22c	43-84-0031	Felt Plug	(2)
31a	43-44-0008	Gearcase Cover Gasket	(1)
33c	34-40-0449	O-Ring	(1)
37	43-44-0118	Lower Gearcase Gasket	(1)
38c	43-42-0093	Motor Shaft Seal	(1)
80	22-16-0031	Brush Service Kit (Set of two brushes)	(1)
	45-00-0230	B118-V2 Grease (50g Tube)	(3)

SCREW TORQUE SPECIFICATIONS

FIG.	PART NO.	DESCRIPTION OF FASTENER	WHERE USED	SEAT TORQUE	
				(kgf-cm)	(lb-in)
29	05-78-0033	M5 x 20mm Pan Hd. T-25 Machine Screw	Upper Rear Bushing	50±5	43.3±4.3
32a	06-82-2873	M5 x 17mm Pan Hd. T-25 Machine Screw	Gearcase Cover	35±4	30.3±3.4
32b	06-82-2873	M5 x 17mm Pan Hd. T-25 Machine Screw	Mid Gearcase Bottom Rear Bushing	80±8	69.4±6.9
32c	06-82-2873	M5 x 17mm Pan Hd. T-25 Machine Screw	Lower Gearcase	70±5	60.7±4.3
33a	06-82-0032	M4 x 12mm Pan Hd. T-20 ST Screw	Mode Selector	18±1.5	15.6±1.3
40	05-78-0032	M5 x 13mm Pan Hd. T-25 Machine Screw	Bearing Retaining Plate	25±3	21.6±2.6
41	05-88-1275	M4 x 70mm Pan Hd. Phillips ST Screw	Fan Baffle / Field	18±1.5	15.6±1.3
46	05-78-5311	M5 x 18mm Pan Hd. T-20 PT Screw	Rear Handle Cover	29±3	25.1±2.6
46	05-78-5311	M5 x 18mm Pan Hd. T-20 PT Screw	Housing Cover	29±3	25.1±2.6
48	05-78-0019	M5 x 25mm Pan Hd. T-25 Machine Screw	Motor Housing	55±5	47.7±4.3
49	05-78-5313	M4 x 9mm Pan Hd. T-15 ST Screw	Brush Holder	15±1.5	13.0±1.3
54	06-82-0044	M4 x 18mm Pan Hd. T-20 ST Screw	Motor Cap	15±1.5	13.0±1.3
56	06-82-8828	#8-32 Pan Hd. T-20 Taptite Screw	Ground Wire	18±2	15.6±1.7
62	06-82-0995	M4 x 16mm Pan Hd. T-20 ST Screw	Cord Clamp	20±2	17.3±1.7

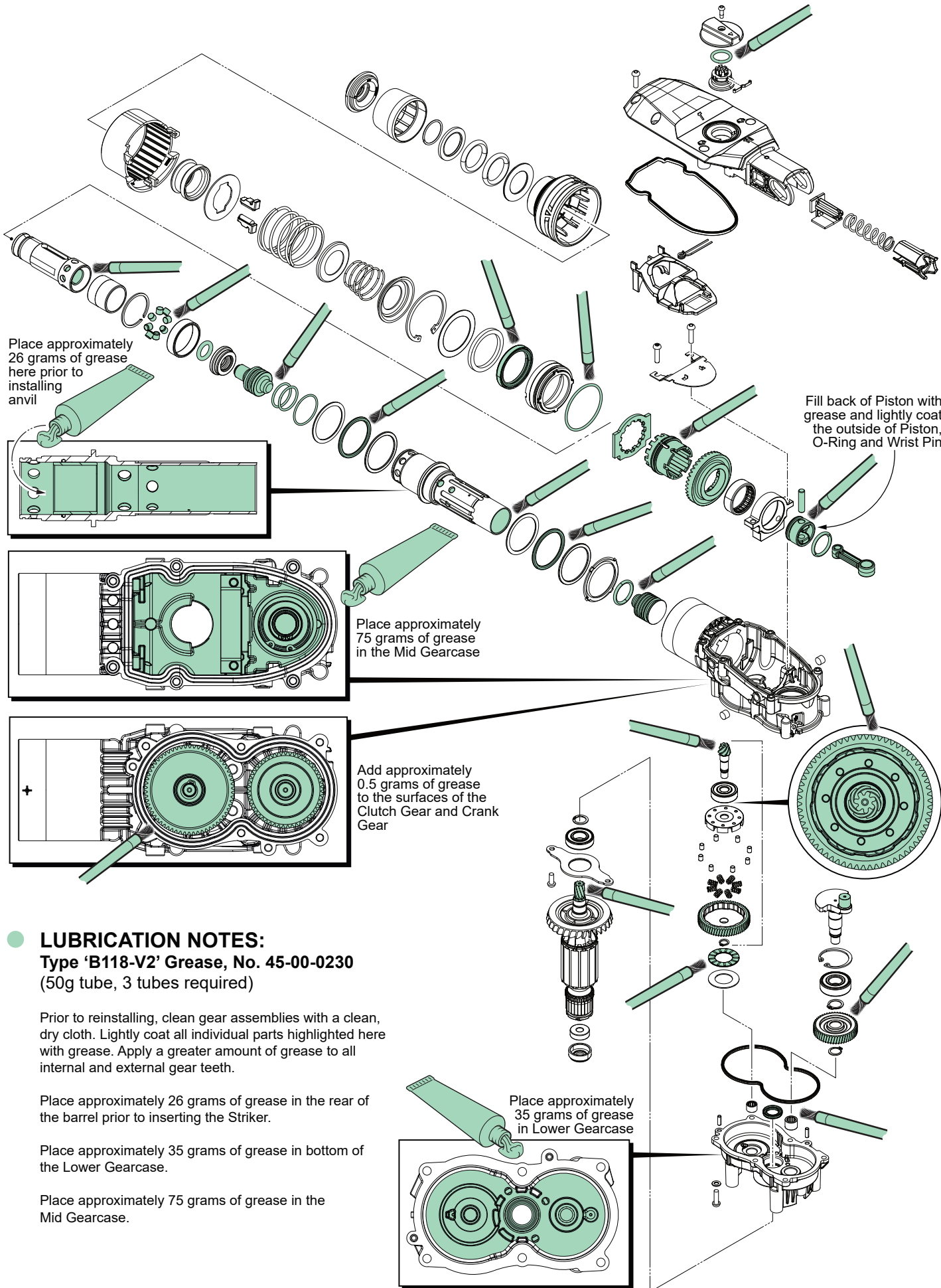

● **LUBRICATION NOTES:**
Type 'B118-V2' Grease, No. 45-00-0230
 (50g tube, 3 tubes required)

Prior to reinstalling, clean gear assemblies with a clean, dry cloth. Lightly coat all individual parts highlighted here with grease. Apply a greater amount of grease to all internal and external gear teeth.

Place approximately 26 grams of grease in the rear of the barrel prior to inserting the Striker.

Place approximately 35 grams of grease in bottom of the Lower Gearcase.

Place approximately 75 grams of grease in the Mid Gearcase.

White wire from the PCBA to white field wire

Red wire from PCBA to red field wire

White wire with flag terminal from PCBA to tab location 2 on switch

Blue PCBA wire to white cord wire

Brown PCBA wire to black cord wire

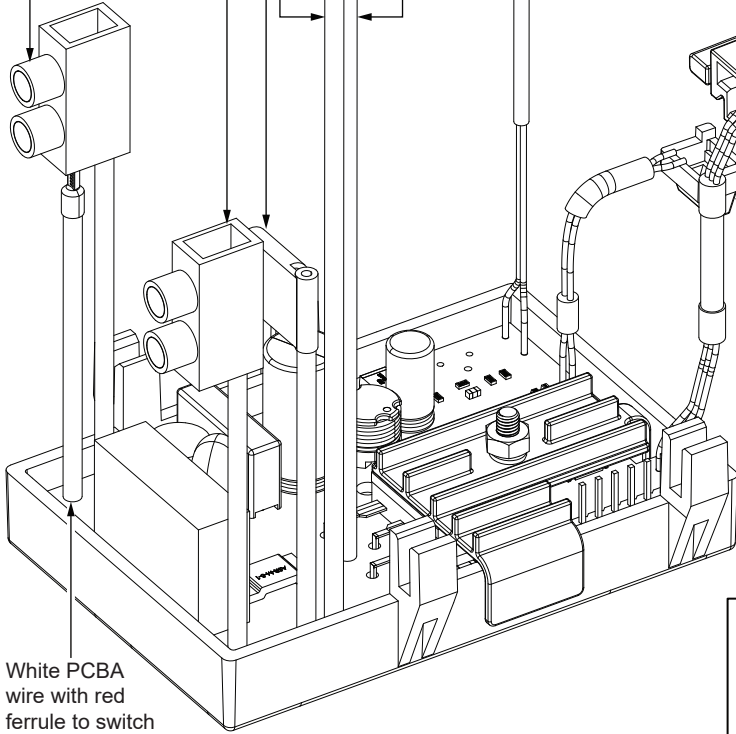

LED Assembly

On-Off Switch

Hall Sensor and Housing

Service LED

Connect white wire with red ferrule from PCBA to switch location 2 ↑

Connect white wire with flag terminal from PCBA to the tab location 2 on Switch

White PCBA wire with red ferrule to switch location 2 ↑

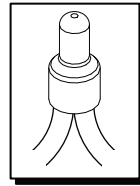

Red and white PCBA wires are to be joined with the corresponding colored field wires using an open end connector

Black field wire to brush holder assembly

White field wire to white PCBA wire. Join with close end connector

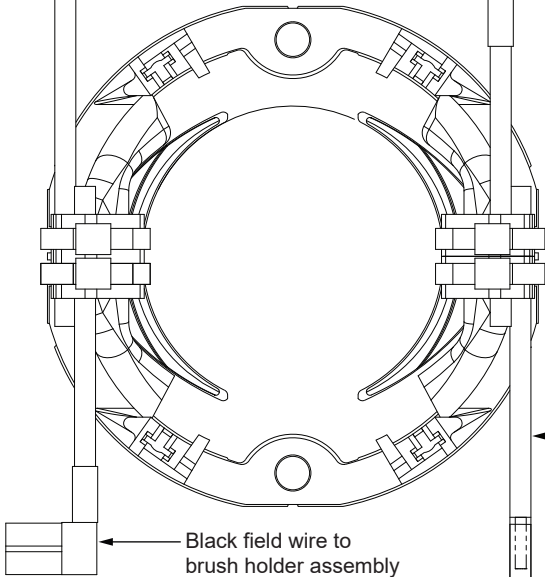

Black field wire to brush holder assembly

Red field wire to red PCBA wire. Join with close end connector

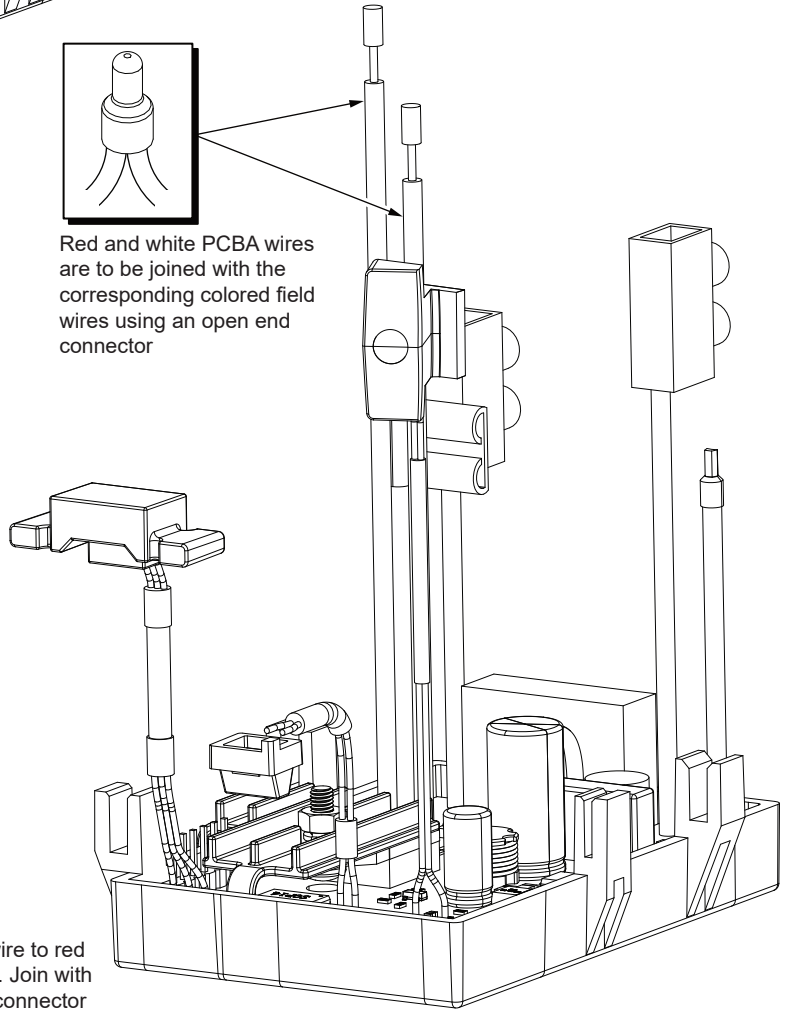

White wire with flag terminal from PCBA

White wire with red ferrule from PCBA

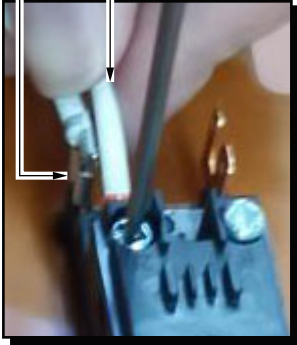

Connector Block joining black and brown wires is to be placed in handle cavity first. Connector Block joining white and blue wires on top in cavity.

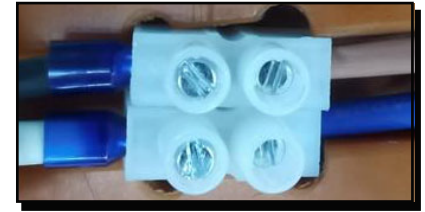

Connector Block joining white and blue wires to be placed on top in cavity.

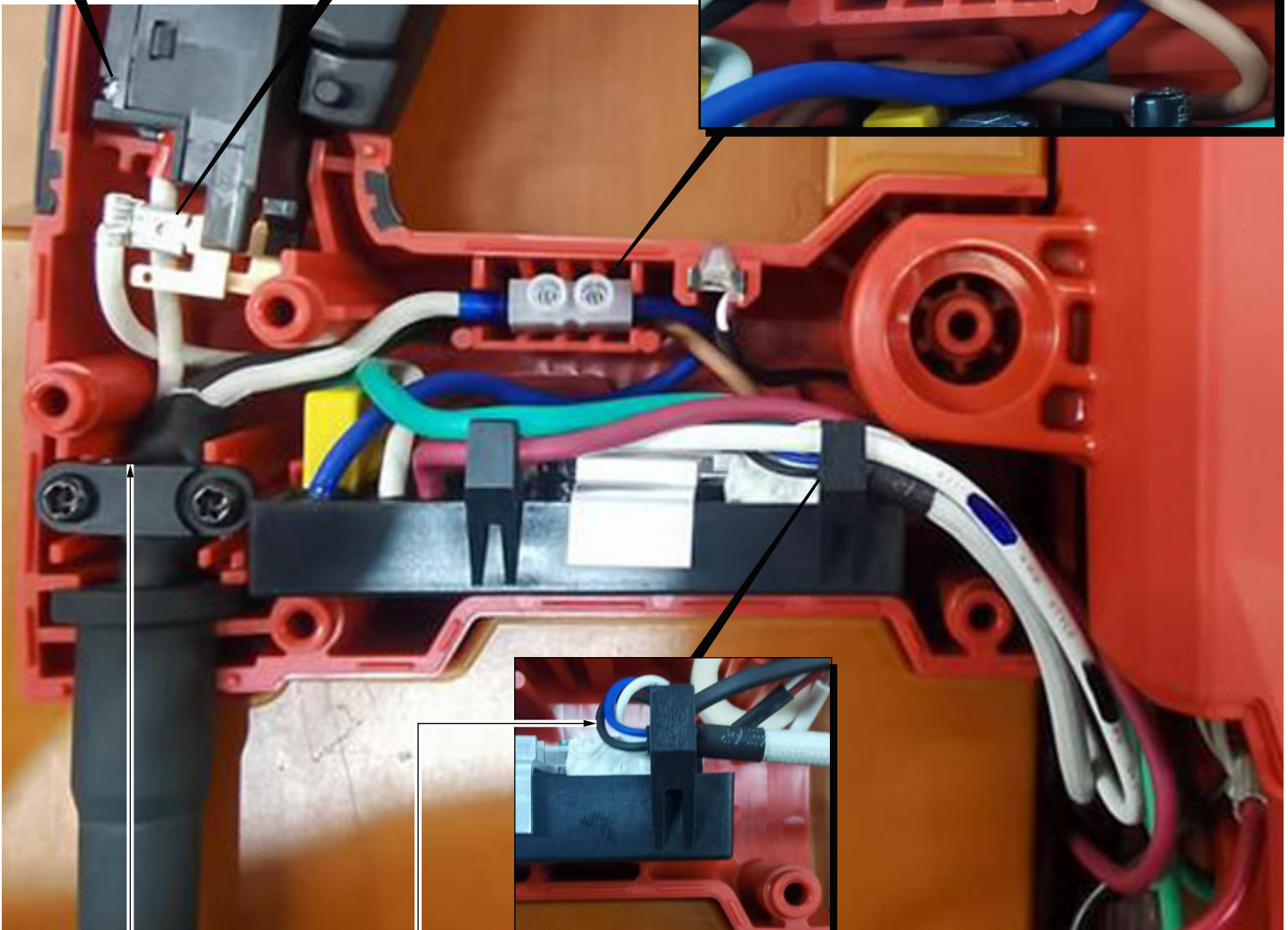
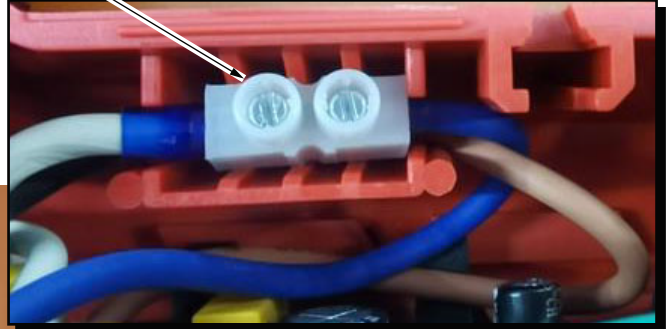

Cord jacket to extend .25" minimum beyond the top of Cord Clamp

Wires for Hall Sensor are to be placed in wire trap first as shown.

Place in the trap, on top of the Hall sensor wires, the white and red PCBA wires and the green ground wire from the cord.

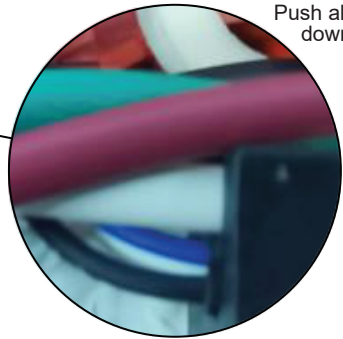
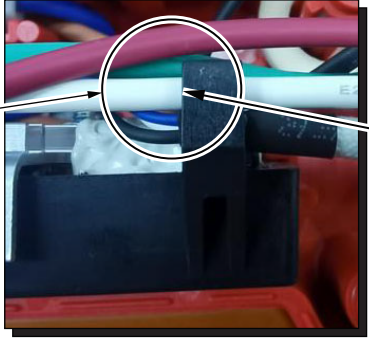
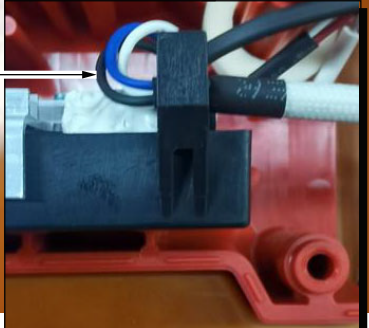

Push all wires firmly down in wire trap

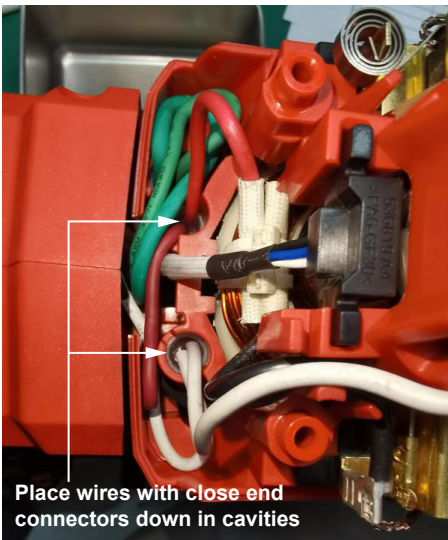
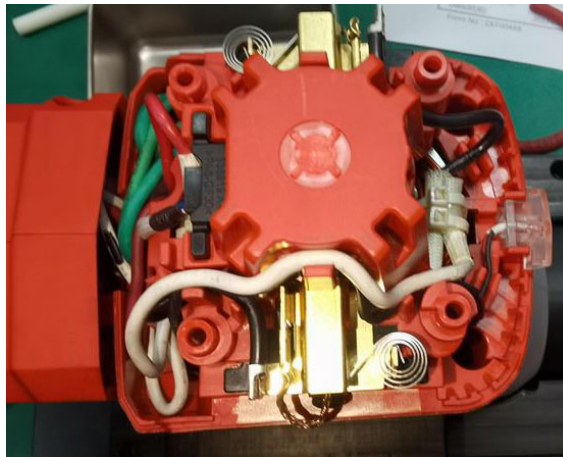
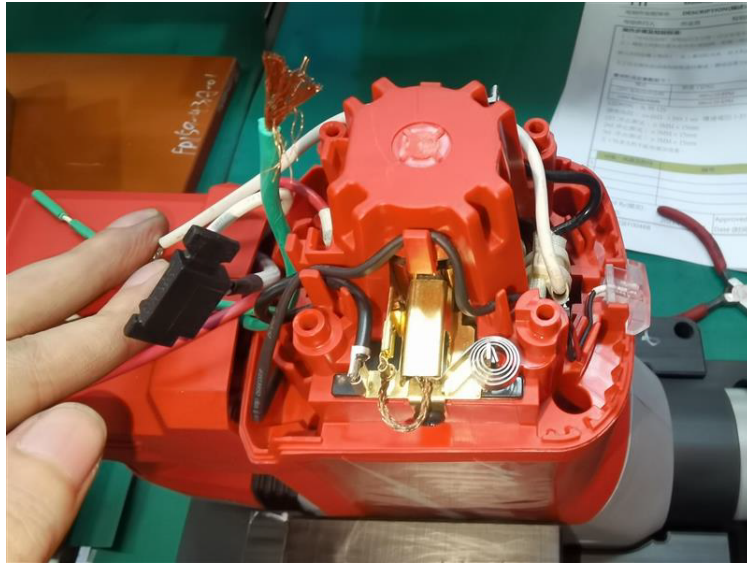
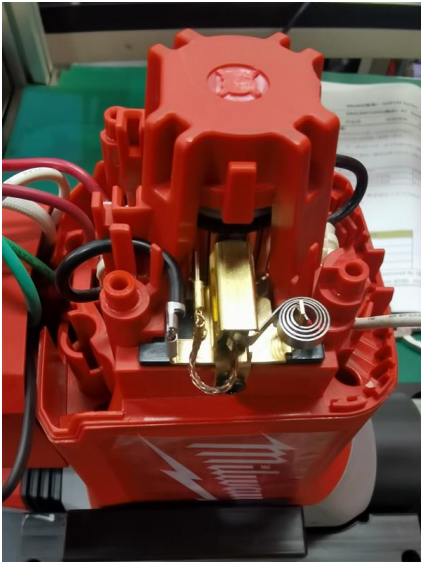

Place wires with close end connectors down in cavities



Photos on this page depict components, wires and wire routing of the electronics package (See page 5).

Install all components firmly and squarely in corresponding cavities of the Motor Housing. Route all wires as shown being sure those placed in wire traps are pressed completely down in bottom of traps. Tuck all excess wires down into Motor Housing cavities to avoid pinching when the housings are reassembled.

As an aid to reassembly, take notice of wire routings and position in wire guides and traps while dismantling tool.

Be sure that all components of the electronics assembly are seated firmly and squarely in housing recesses.

Avoid pinched wires, be sure that all wires and sleeves are pressed completely down in wire traps.

Prior to securing housing Motor Cap onto the Motor Housing, be sure that there are no interferences.

Check for proper functionality of shuttles, buttons and triggers prior to powering tool.